

COMFORT SERIES™ SSD05232 ACCESSIBLE BATHTUB



•EXCLUSIVE•
Installation-Included
or choose
Installation-Ready

In our aging society, bathrooms present serious challenges for those who are aging, or with mobility, accessibility issues. ComfortSeries™ accessible home & health care bathtubs by American Standard offer a solution for these challenges.

Designed to fit in the same space as a regular 60" bathtub, the full-sized, contoured water-tight door swings outward, allowing ease of entry and exit. The 17" ADA right-height seat makes it easier to transfer from a standing position, walker or wheelchair for barrier-free entry, and provides unrestricted access to the bather in the event of a medical emergency.

ComfortSeries™ bathtubs feature and include RevitaJet® Whole Body 44 Jet Hydrotherapy System to treat illness and injury, symptoms of arthritis, back pain, circulatory disorders and other common impairments; and in eliminating toxins that cause joint pain and inflammation.

Fitted with an In-Line heater to maintain consistent bath water temperature, and the Ozone Sanitation ensures a hygienic and bacteria-free spa bath. Our engineered and patented QuickDrain® is a powered pump that evacuates water in less than 2 minutes, allowing for a quick and safe exit. Bathe and shower safely and independently while taking an active role in your overall wellness.

You want only the BEST. ComfortSeries™ delivers Safety & Accessibility, and Health & Spa Wellness; backed by the best limited LIFETIME WARRANTY from the most trusted 150-year manufacturer, American Standard.

RevitaJet® Whole Body Hydrotherapy System:

Choose your desired settings for total body indulgence that can calm and comfort, or refresh and revitalize you.

Hydrotherapy uses water to deliver temperature and pressure changes to the body through buoyancy, heat, blood flow & circulation. Natural buoyancy and submersion in water decreases your body weight by up to 90% that can alleviate and diminish joint pressure, swelling, and muscle pain.

Heated massage from jets activates nerves in the skin and muscles, increasing blood circulation to the massage area. This results in tissue oxygenation, toxin evacuation; assisting in easing pain in a bather's joints and allowing muscles to relax and help injuries heal faster.

Whirlpool Massage

A soothing and invigorating water jet massage system allows you to customize back and leg muscle therapies with 15 different water jets, 6 of which are directional.

Designed to relieve aches & pains from symptoms of arthritis, inflammation and injury; the additional Ultimate Leg & Foot Therapy selection provides pain and stillness relief, and promotes comfort and restful sleep.

Includes an In-Line Heater, and automatic Ozone Sanitation System.

AirSpa Massage

Experience a soft and caressing all-over body massage powered by a separate dedicated variable speed heated blower that releases thousands of air bubbles from 29 different air jets throughout the water. The tingling sensation from the bubbles on your skin, causes neural reflexes to activate, promoting muscle relaxation and contentment.

The automatic purge cycle eliminates residual water to help keep the system running efficient and clean.

Chromatherapy & Aromatherapy

Multi-coloured LED Light and aroma therapies encourage mental wellness through visual and sensory stimulation. Select from 7 colours and 4 included aromas for the ultimate bathing experience.

QuickDrain® System

Our patented innovation that once activated, rapidly pumps the water out in less than 2 min, making it safe to open the door and exit the bathtub. A must, in case of an emergency.

americanstandardwalkintub2u.com

COMFORT[®]SERIES™ SSDOD5232 52"x32" OUTWARD-OPENING DOOR ACCESSIBLE BATHTUB



ACCESSIBILITY FEATURES

- free-standing SS support frame with 5 adjustable levelling feet—fits 60" alcove openings
- 34" (864mm) wide outward-opening wheelchair accessible door/seat for ease of entry, exit & full seat transfer
- contoured 17" (432mm) chair-height integral transfer seat
- dual-locking, pressure sealed leak-free outward swing door system
- embossed backlit Touch Control Pad with vision-impaired button identifiers
- barrier-free lever faucet handles & hand-shower diverter
- removable panel accommodates patient lift—for wheelchair transfer
- door is designed to open over nearby toilet and/or obstructions
- Arthritis Foundation 'Ease of Use Commendation' and Arthritis-Friendly

SAFETY FEATURES

- patented QuickDrain[®] fast water removal system
- built-in safety grab bar
- textured floor surface
- premium American Standard fast-fill bath filler faucet and hand-held multi-spray shower wand with stainless steel shower hose
- polished chrome colour contrasting fittings for optimal visuals:
 - built-in safety grab bar
 - drain trim and cable-driven waste & overflow trim
 - whirlpool and air jet trim
- all features and function operations are within arms reach

HEALTH FEATURES

RevitaJet™ Whole Body Hydrotherapy System with:

- 7amp whirlpool pump
- multi-speed heated air pump
- 44 Massage Therapy Jets—targeting back, hips, knees, legs, feet & wrists:
 - 15 variable flow water massage jets; 6 are directional
 - 29 seat & floor air injectors with multi-speed heated blower
 - Legs-Only Massage System—focused circulation therapy
- Chromatherapy LED Light System—visual & mental wellness therapy
- Aromatherapy System—sensory & mental wellness therapy
- In-Line Heater—maintains ideal temperature
- Ozone Sanitation System—water oxygenation and bacteria removal
- automatic Purge Cycle—eliminates residual water and prevents mold

CONVENIENCE FEATURES

- cushioned neck pillow
- accommodates reverse plumbing—focus on access first
- bathtub extender kit—retrofit into a 60" (1524mm) alcove space
- *Personalized Service*—bathroom assessment & selection support
- installation* service included, or select RTC (Ready-to-Connect)
- Lifetime Warranty on complete product including installation/labour*

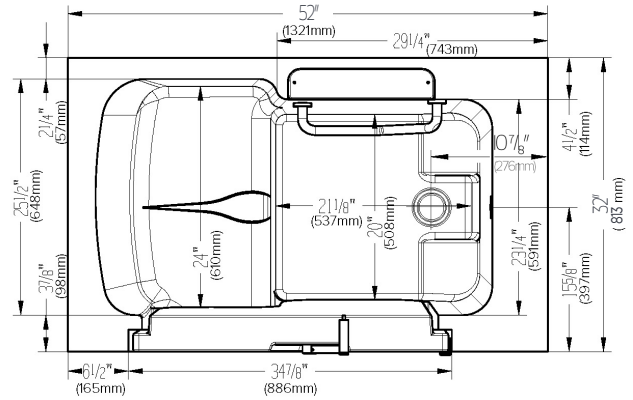
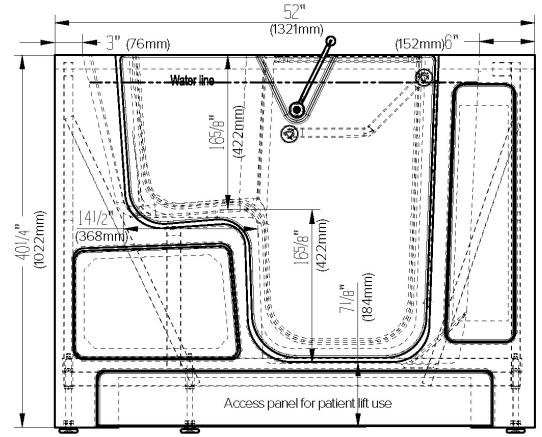

GENERAL SPECIFICATIONS FOR SSDOD5230 ACCESSIBLE BATHTUB

INSTALLED SIZE	52"x32"x40" (1321x813x1016mm)
WEIGHT	161 lbs (73 kg)
WEIGHT w/WATER	828 lbs (376 kg)
OPERATING GALLON	80 gal (303 L)
FLOOR LOADING	73 lbs/sq.ft (356 kg/sq.m)
PROJECTED AREA	38.5 cu.ft (1.09 cu.m)

To Be Specified - Required:

- Drain Configuration: Left (CLD) or Right (CRD)
- Colour: White (W) only

Options:

- Handshower Safety Glide Bar—24"
- SuperPole: White (W) only



Lifetime Warranty coverage includes bathtub, all components, door seal, faucet. Lifetime Warranty is extended to installation/labour* when completed by American Standard Walk-in Tubs Canada

Designed to improve mobility & make life easier



Designed for pain relief & easy use



Notes: The whirlpool heater is designed to maintain water temperature during operation. It will not heat cold water to desired temperature. Tub is supported by the frame, and five integrated adjustable feet. Additional support is not required. Refer to installation instructions supplied with tub, for additional information. Provide suitable reinforcement to sub floor for all supports.
 Our products are in compliance with the following codes: Uniform Plumbing Code UPC[®] and Canadian Uniform Plumbing Code c UPC[®], National Plumbing Code of Canada, International Plumbing code IPC[®].
 Our products conform to the following standards: UL-1795, ASME A112.19.7/CSA B45.10, ASME A112.19.15, CSA B45, CSA B45.5/ASMO Z124.1.2, CSA C22.2 No218.2, CSA B652 for accessible homes;
 Our products are listed with: cETLus.
IMPORTANT: Dimensions of fixtures are nominal, may vary, and are subject to change or cancellation. No responsibility is assumed for use of superseded or voided leaflet.